

PFAS-Free Environmental Sensor Packaging

8" / 200 mm Si wafer with integrated gas permeable PFAS-free environmental protection caps for MEMS

MEMS gas and pressure sensors must be protected against harmful environmental influences such as particles or condensing moisture. Conventionally, the integration of protective caps is a single chip process. At Fraunhofer ISIT, the unique PowderMEMS® process offers the capability to produce PFAS-free gas permeable protection caps embedded in 8" / 200 mm silicon substrates. These cap wafers can be directly bonded to MEMS wafers – eliminating the need for single chip processes. Other functionalities such as heaters or catalytic internal surfaces for the removal of interfering gases¹ can be developed depending on customer requirements.

Technology

The PowderMEMS® process is based on the agglomeration of microfine powders by atomic layer deposition (ALD). First, DRIE-etched microcavities in a silicon substrate are filled with loose powder and the substrate is introduced into an ALD reactor. The gaseous ALD precursors then penetrate the entire particle bed, leading to the controlled growth of a rigid layer around each particle. This creates a stable and porous three-dimensional structure. With PowderMEMS®, porous structures with dimensions between 30 micrometers and several millimeters can be realized with high precision.²

Our services:

- Customer-driven development of gas permeable environmental protection caps
- Concept design, manufacturing, and characterization
- Pilot production in 8" / 200 mm MEMS fab and dedicated PowderMEMS® facility

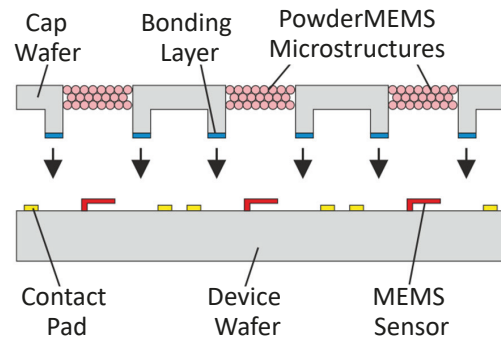

Wafer bonding of a PowderMEMS wafer with integrated gas permeable environmental protection caps to a MEMS device wafer

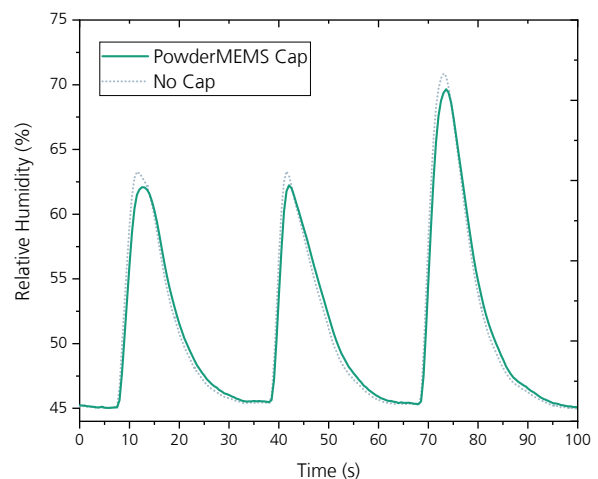
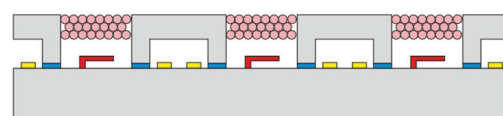

Performance of a commercial MEMS humidity sensor modified with a 400 μm thick gas permeable PowderMEMS environmental protection cap (solid line) compared to a stock sensor (dotted line)

PFAS-Free Environmental Sensor Packaging

MEMS R&D at Fraunhofer ISIT

Professional MEMS production line

- Development and production: 8" / 200 mm wafer technologies (silicon and glass)
- ISO 5 BEOL cleanroom
- Critical Dimension: 0.35 μm
- Installed capacity: 800 wafers per month
- Chemical-mechanical polishing (CMP) facility
- Wafer grinding and dicing facility

PowderMEMS® production line

- Dedicated atomic layer deposition (ALD) tool for 8" / 200 mm wafers
- Custom tooling for automated filling of wafers with dry powders
- Optical and magneto-optical inspection for characterization and quality control
- Custom tooling for magnetization of 8" / 200 mm wafers

MEMS cleanroom at Fraunhofer ISIT
Discover our cleanroom in a 360° tour: s.fhg.de/isit360

Contact

Dr.-Ing. Ole Behrmann
+49 4821 17-3417
ole.behrmann@isit.fraunhofer.de

Fraunhofer Institute for Silicon Technology ISIT

Fraunhoferstraße 1
25524 Itzehoe, Germany

<https://s.fhg.de/PowderMEMS-EN>

